

TRU-BEAM

COLOR DAY/NIGHT INFRARED

MODEL#: RGDNIR-49



Used with Sony Super HAD CCD and its DSP technology, these cameras reproduce extremely clear color images at a resolution of 500 TVL. The image instantly changes from Color to B/W at 5 lux automatically, and its horizontal resolution at night is increased up to 560 TVL.

The external zoom and focus knob enables customers to control zoom/focus simply by hand externally. The unit has passed the IP67 testing and guarantees interior moisture, condensation-free picture in any harsh weather condition.

Features include:

- 1/3" Super HAD DSP Color CCD Sensor (SONY)
- 500 TVL Horizontal Resolution
- Remarkably True Color reproduction
- Lens: 4~9mm Varifocal
- Auto Iris Lens control (DC-Iris)
- Excellent Back Light Compensation
- Excellent Auto White Balance
- Extremely reliable power input range
- Reverse Polarity Input protection circuit built-in
- Zoom and Focus External adjustment

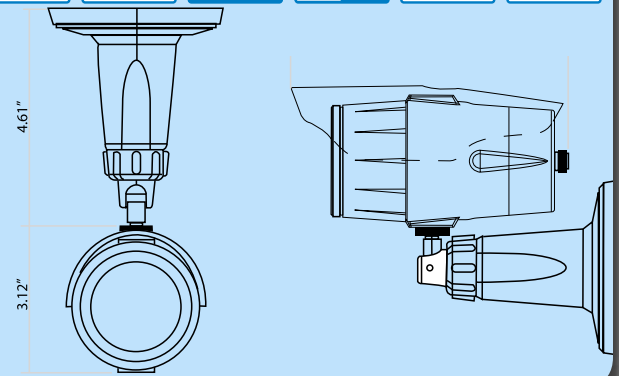

Image Sensor	1/3" High Resolution Sony Super HAD Color CCD
Effective Pixels	NTSC: 768 (H) x 494 (V) PAL: 752 (H) x 582 (V)
Horizontal Resolution	500 TV Lines - Color at Day, 560 TV Lines BW at Night
Day & Night	True DN w/ICR
Sync System	Line lock
Scanning System	NTSC 525 Lines / PAL 625 Lines 2:1 Interlaced
Video Output	1.0Vp-p Composite. 75 Ohms
Min. Illumination	0.2 Lux at F1.6 w/o LED, 0 Lux with LED
BLC	On/Off (with DIP SW)
White Balance	2100°K ~ 9100°K Auto
Gain Control	0dB - 32dB Auto
Gamma correction	r=0.45
Smear effect	0.005%

Shutter speed	NTSC: 1/60~1/100,000 sec PAL: 1/50~1/100,000 sec
LED spectrum	850nm 20 ° IR LED x 20 each
IR Beam Distance	2-20M (65ft)
IR LEDs MTBF	20,000 hours (more than 4 years)
Power source	12VDC
Operation current	120mA (IR off), 340mA (IR on)
Lens (filter removable)	STD: 4-9mm varifocal DC Iris lens
Operating Temperature	14°F ~ 122° F (-10°C ~ +50°C)
Humidity	Within 90% RH
Measurement (mm)	60(D) x 127.5 (L)
Weight (approx. g)	1300
Optional Feature	external audio with C-Micro- phone "-35dB / mV"

Toll Free: 866-301-CCTV