



STERN WATCH MONITORING SYSTEM

Monitor and Camera Package



STERN WATCH CAMERA

The **Stern Watch Camera** offers superior durability and unmatched versatility in an all-weather camera.

This distinctive design features dual viewing windows, allowing the camera to be either ceiling, wall mounted or stern without requiring a bracket. The camera position within the enclosure is fully adjustable, increasing the range of possible viewing angles.



Stern Watch Camera Features and Benefits

Stainless Steel Enclosure

Designed for extra rigidity and strength, while maintaining light weight and excellent aesthetic appeal

Interchangeable viewing windows

Camera can be ceiling or wall mounted while providing a large viewing area in all orientations

Lexan MR 10 1/4" viewing window

This polycarbonate window offers ultra-high impact and scratch resistance with superb optical quality

Single Security Screw

This security screw reduces the risk of tampering

Electrically isolated Camera

Help eliminate ground loop problems

Uniquely designed internal camera mount

The adaptable mount is easy to adjust to all viewing angles

High quality Sony imaging devices

Excellent light sensitivity and low noise design ensures superior images even in low light conditions

Optional Infrared Available

An enclosure formed from stainless steel provides a rugged yet lightweight design. The IP rating of 66 means that the camera is both dust and water resistant.

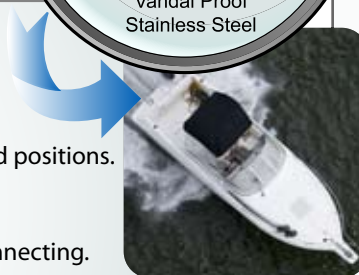
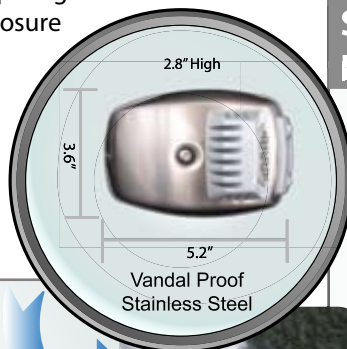

Can be mounted on back deck siding, ski racks, top deck, radar arches just to name a few. Possibilities are limitless.

Cam alone looks like a bilge vent.

Pre-Assembled and can be set up for left, right and overhead positions.

Pre-Adjusted and pre-focused for crystal clear video.

Pre-Wired with long leads to go through the wall before connecting.

High resolution SONY camera parts for beautiful picture and long life.

Exclusive TWO YEAR WARRANTY

STERN WATCH MONITOR

This amazing 7" LCD fits into your boat with ease.

You can flush mount it or use the provided stand.

Looks like a fish finder and can be wired directly into your boat's wiring.

Remote control included.



STERN WATCH CAMERA SPECS



CAMERA HOUSING

Enclosure Material	Formed stainless steel, electrically isolated from camera
Viewing Windows	Dual position, anti-glare, scratch-resistant, high-impact Lexan MR-10
Mounting Options	Rear Deck or Wall, no bracket required
Enclosure Size	Width 92mm 3.6" Length 132mm 5.2" Height 70mm 2.8"
Weight	500g 16oz
Environmental Rating	Designed to IP 66 (Outdoor, high-pressure water resistant)

ELECTRICAL

Voltage Range	11 VDC- 18 VDC
Transient Protection	1.5 kW

LUX LEVELS

Lux	color-0.9 / Day/Night-0.1
-----	---------------------------

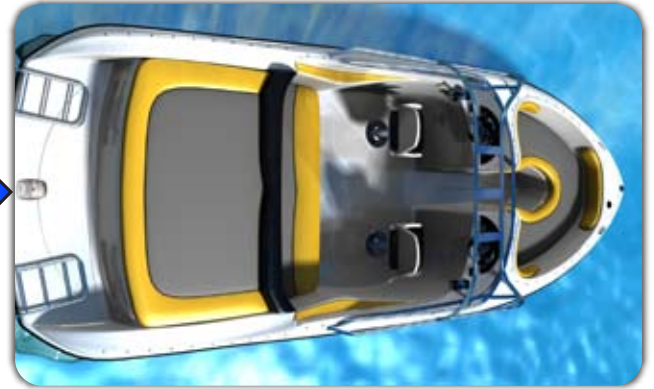
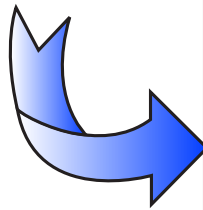

Resolution & Available Lenses

	Size (mm)	F-Stop	Viewing Angle (v)	Viewing Angle (h)
Resolution 480 TV Lines	2.97	2.0	67°	90°

STERN WATCH MONITOR SPECS

Display	Active Matrix TFT LCD
Resolution	480 x 234 VGA
Display Colors	16.7 Million Display Colors
Contrast Ratio	300:1
Brightness	400 cdm2
Dimensions	5.3"H x 7"W x 1"D
Power	12V DC and Remote Control



201 North Elm Street • Kemp, Texas 75143

Toll Free: 1-866-301-CCTV • Phone: 903-498-3240 • Fax: 903-498-8989

Websites: www.rugged-cctv.com • email: techsupport@rugged-cctv.com